

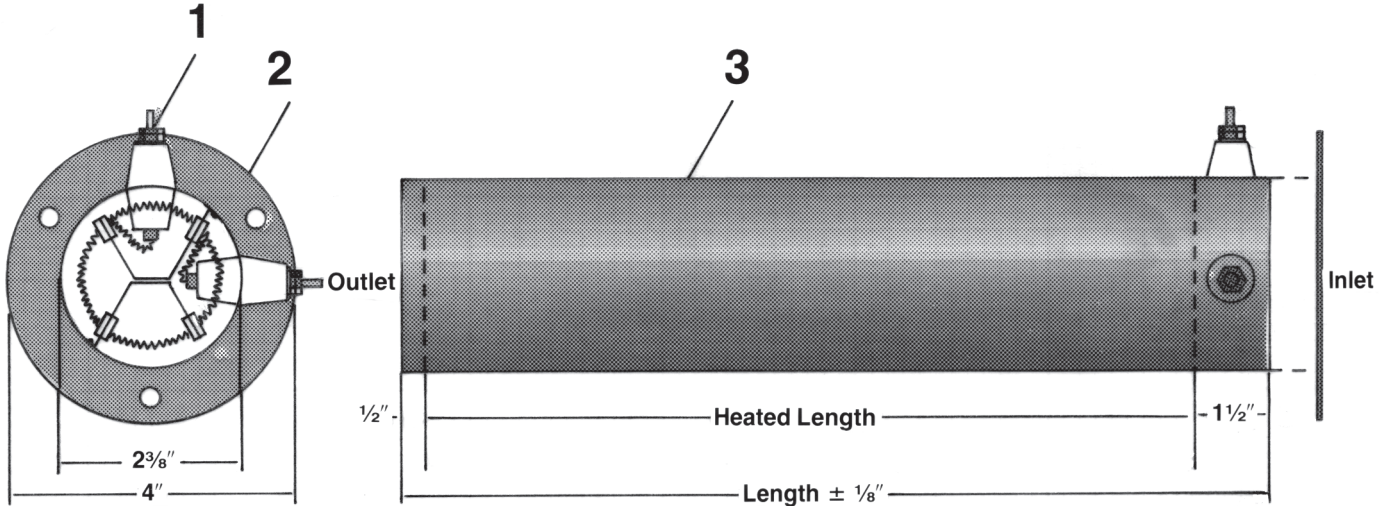

Air Process Heaters

Maximum Flow

U.L. Recognized - E56973
CSA Certified - 016386-0-000



AIR

Features

- This Maximum Flow Air Heater design is encased within a 2 3/8" O.D. tube with a cross frame heating element for minimum resistance to air flow. It has a practical operating range of up to 200CFM with temperatures to 600°F (315°C).
- For easier mounting, Hotwatt can supply a 4" O.D. mounting flange on one or both ends.
- The heater is available in either aluminum or stainless steel.
- Its design features include a nickel-chrome heating element insulated by ceramic beads on a stainless steel support frame, firmly secured to the inside of the tube.
- Designed for high volume and moderate temperature.
- Low pressure for use with blowers and recirculating air.
- Made in U.S.A.

Specifications

Maximum Amperage: 15

Cross Sectional Flow Area: 3.5 sq. in.

Aluminum Sheath		Stainless Steel Sheath	
CFM	Max. Watts/linear in. of heated length	CFM	Max. Watts/linear in. of heated length
1	150	1	150
2	150	2	150
4	150	4	150
6	150	6	150
8	150	8	150
10	150	10	150
20	175	20	250
30	275	30	375
40	350	40	475
50	450	50	600
60	525		

Applications

Baking, Drying, Packaging, and preheating.

Construction

- 1 Post Terminals.
- 2 **Optional** flanges—4" O.D. with three 9/32" diameter holes equally spaced on 3.250 circle—one or both ends.
- 3 Standard aluminum sheath – optional stainless steel sheath.

▼ Manufactured Items ▼

Sizes

Length	Heated Length	Cat. No.	Cat. No. 4" O.D. flange at entry end only
6"	4"	MA0-6	MA0-6F1
8"	6"	MA0-8	MA0-8F1
10"	8"	MA0-10	MA0-10F1
12"	10"	MA0-12	MA0-12F1
14"	12"	MA0-14	MA0-14F1
18"	16"	MA0-18	MA0-18F1
24"	22"	MA0-24	MA0-24F1

- 3 Phase not available in this unit.

Consult factory for:

Current ratings above 15 amps.
Wattages above 300 watts per linear inch.
Longer lengths and larger sizes available.

Special Features:

Add suffix to catalog number

F1: **Optional** flange inlet end.

F2: **Optional** flanges each end.

SF37: Stainless steel sheath.



Air Process Heaters

Maximum Flow

▼ IN STOCK ITEMS ▼

Maximum Flow Heaters: with standard entry flange.

Supplied with: Type SF3 terminals. Type SF13A enclosure.

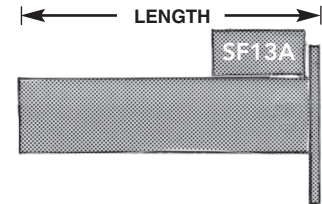

Length	Cat. No.	Dia.	Wattage	Voltage	Watts/ Linear Inch	Weight	Terminals
6"	MA0-6F1	2 $\frac{3}{8}$ "	600	120	150	.05	S&N w/enclosure
10"	MA0-10F1	2 $\frac{3}{8}$ "	1000	120	125	1.25	S&N w/enclosure
12"	MA0-12F1	2 $\frac{3}{8}$ "	375	120	38	1.50	S&N w/enclosure
12"	MA0-12F1	2 $\frac{3}{8}$ "	1500	240	150	1.50	S&N w/enclosure
14"	MA0-14F1	2 $\frac{3}{8}$ "	500	120	42	1.75	S&N w/enclosure
14"	MA0-14F1	2 $\frac{3}{8}$ "	2000	240	166	1.75	S&N w/enclosure

AIR